

2024 REC Build Guide

Supplies needed to build **half** of the 4-H REC Field for 2024:

- [4' x 8' plywood board, 19/32" depth](#) (1)
- 2-inch wide Gaffers tape (1 each of white, blue, and red)
- 1-1/2" wide Continuous Piano hinge – comes with screws (Longer lengths would need to be cut into pieces at least 5" in length-ideally 6")
 - Piano hinges available in 4-foot lengths ([Home Depot](#) or [Lowe's](#)), 1-foot lengths ([Lowe's](#) or [Home Depot](#)) and as individual, pre-cut hinges in 2-packs ([Lowe's](#) or [Home Depot](#))
- Standard-sized wiffle balls, from toy stores, Wal-Mart, [Amazon](#), etc. (20 balls)
- 1.5" x 1.5" wood cubes: build own or [Madison Mills brand at Lowe's](#) (26 cubes)
- .5" x 2.5" Hex-Head Lag screws at [Lowe's](#) or [Home Depot](#) (16 screws)
- 3" x 5" Notecards or colored construction paper cut to size (2 each of black, white, and red)
- Paint (spray, brush, etc.) or other coloring fluid in green, red, black, and white
- Electric saw

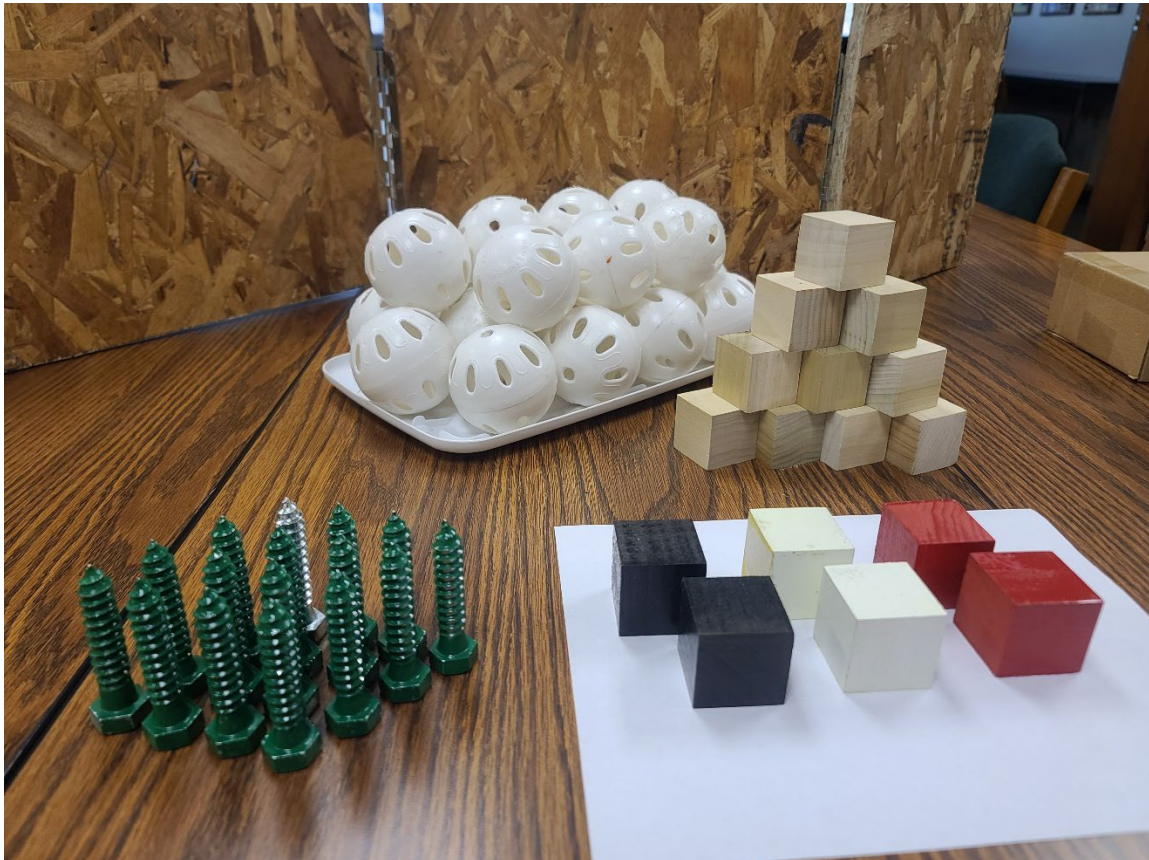
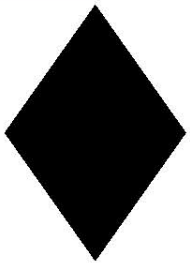
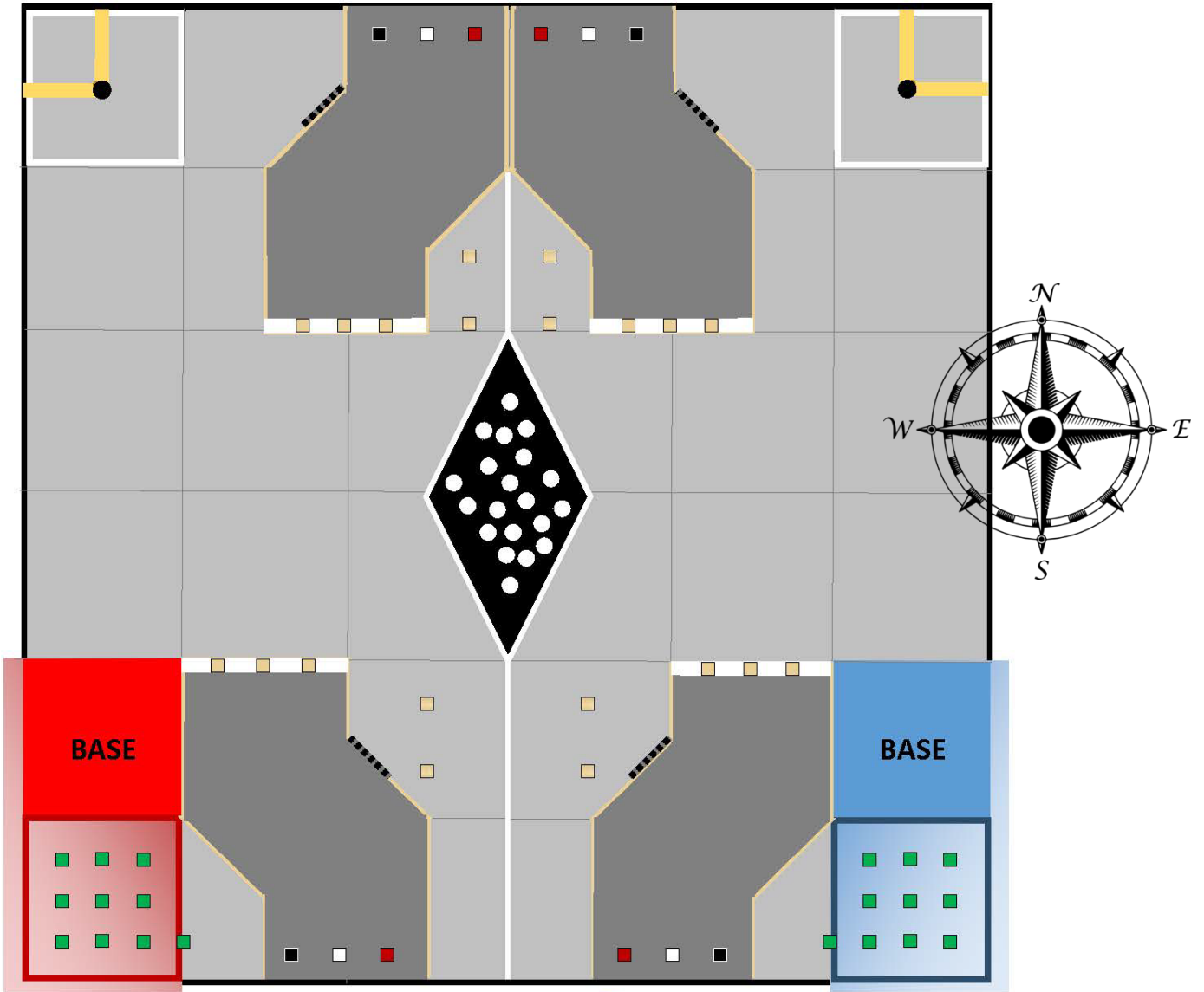

Image of all Lag Screws, blocks, and balls needed for each **half** of the 2024 field



= CANYON

■ = COAL

□ = DIAMOND

■ = REDSTONE

■ = NEW TREES (AKA SAPLINGS)

■ = LUMBER

○ = COBBLESTONE

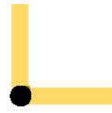

= FURNACE (1 ft. TALL WOOD BARRIER)

White border = DEPOSITORY



= DRIVER-STATIONS (Outside Bases)



= MINING REGION

▤ = COLOR INDICATOR (NOTECARD, RANDOMIZED PRE-MATCH)



Lag Screws can be bought individually or in packs at a reduced per unit cost



Plywood is 19/32" depth, available in 4' x 8' and 4' x 10' sizes

All tape used is standard 2-inch wide Gaffers tape available at home improvement stores, [AndyMark](#), [Amazon](#), or akin.

Plywood used is 19/32' depth, available at Home Depot and Lowe's, and should be one of the cheapest options available. They are usually available in 4' x 8' and 4' x 10' sizes. Building half of the field requires a single 4' x 8' plywood board, which will also leave extra wood that can be used in case of damage or miscuts, while the entire field can be built using a single 4' x 10' plywood board. The full count of plywood pieces needed for half of a field are:

- 12" x 12" (6)
- 24" x 12" (4)
- 17" x 12" (2)

For a full field, multiply the quantities needed above (in parentheses) by two. A potential layout of 4' x 8' cutout of the field pieces needed follows:

| | | | | | | | | | |
|-----|-------|-----|-----|-------|-----|--|-------|-----|-----|
| 12" | 12" | 24" | 24" | 17" | 17" | EXTRA | EXTRA | | |
| 12" | 12" | | | 12" | 12" | | | | |
| 12" | 12" | 24" | 24" | EXTRA | | | | 12" | 12" |
| 12" | EXTRA | | | 12" | 12" | | | 17" | 17" |
| 12" | 12" | | | | | 19/32" 4 x 8 plywood Plywood Pieces for half of 2024 REC field | | | |

Furnace:

The furnace requires two 1' x 1' foot pieces of plywood, attached by a hinge piece. The wood pieces will stand upright when used in the game.



Place the two plywood pieces next to each other on the ground, then carefully place the knuckle of the hinge between the two pieces of plywood (facing down), while keeping the wood as straight as possible, and so the hinge's leaves are flush with the plywood.

Components of a Hinge

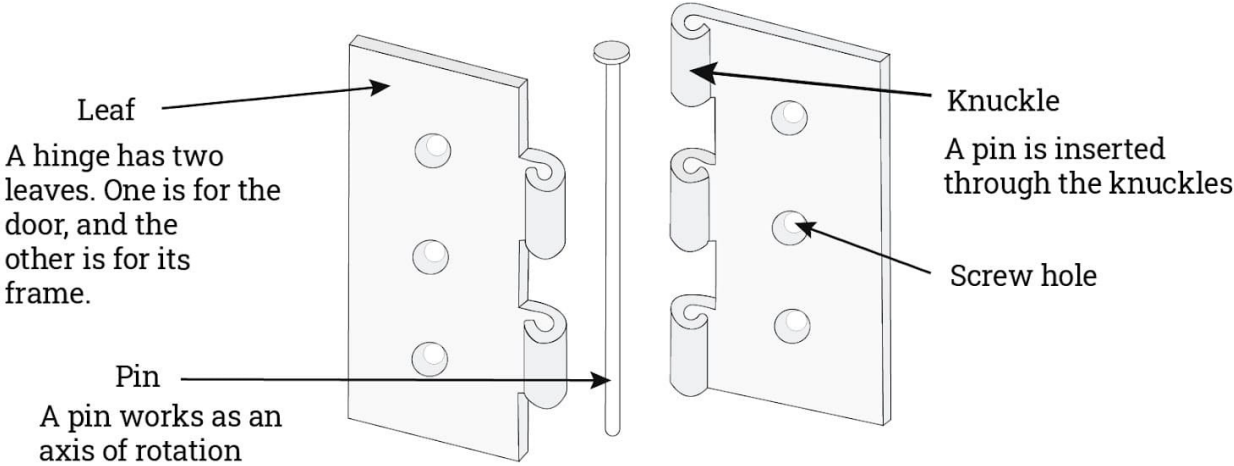

Using a 6" hinge, to center the hinge on the wood height-wise, this means there should be 3" above and below it when it is screwed into the wood. Use a ruler and pencil if needed to mark 3 inches from both the top and bottom of the line where the two pieces of plywood meet. If done correctly, it should fold out and be able to stand at a 90 degree angle as follows:



Mining Region Barriers:

Each half of the field has two Mining Regions that the team playing on that side can collect blocks from to score. Each Mining Region is created by a 2-foot long piece of white tape and two “Z-shaped” plywood barriers, placed on opposite sides of the Mining Region. Each plywood barrier is comprised of 3 pieces of plywood, attached by 2 hinges. Each barrier requires one each of:

- 1' x 1 ft Plywood piece
- 1' x 2 ft Plywood piece
- 1' x 17 inch Plywood piece

The 17 inch plywood piece is used to create a 45 degree angle between the 1 ft piece and 2 ft piece as shown below.



When assembled and oriented correctly, the structure should be able to reach two feet in length, while also simultaneously measuring 13.25" wide (+/- 1/8 inch).

After cutting the boards, the same size hinges that were used for the furnace should be used to connect the Mining Region barrier's wood pieces to each other. The placement of the hinge should be the same as well, midway from the top of the board to the bottom, with the hinges screwed in while the board pieces are right next to each other, as flush as possible with minimal space in between.



Each of the four Barrier walls on a team's side should be built exactly the same, with each wall requiring two hinges. The hinge connecting the **1x1** plywood piece to the 17"x1' piece should be attached so when it is set up, it is located on the **exterior** of the Mining Region itself. The hinge connecting the **2x1** plywood piece to the 17"x1' piece should be attached so when it is set up, it is located on the **interior** of the Mining Region itself. This is done for consistency's sake and to assist with folding and storage as needed. Pictures follow showing these placements from different perspectives.

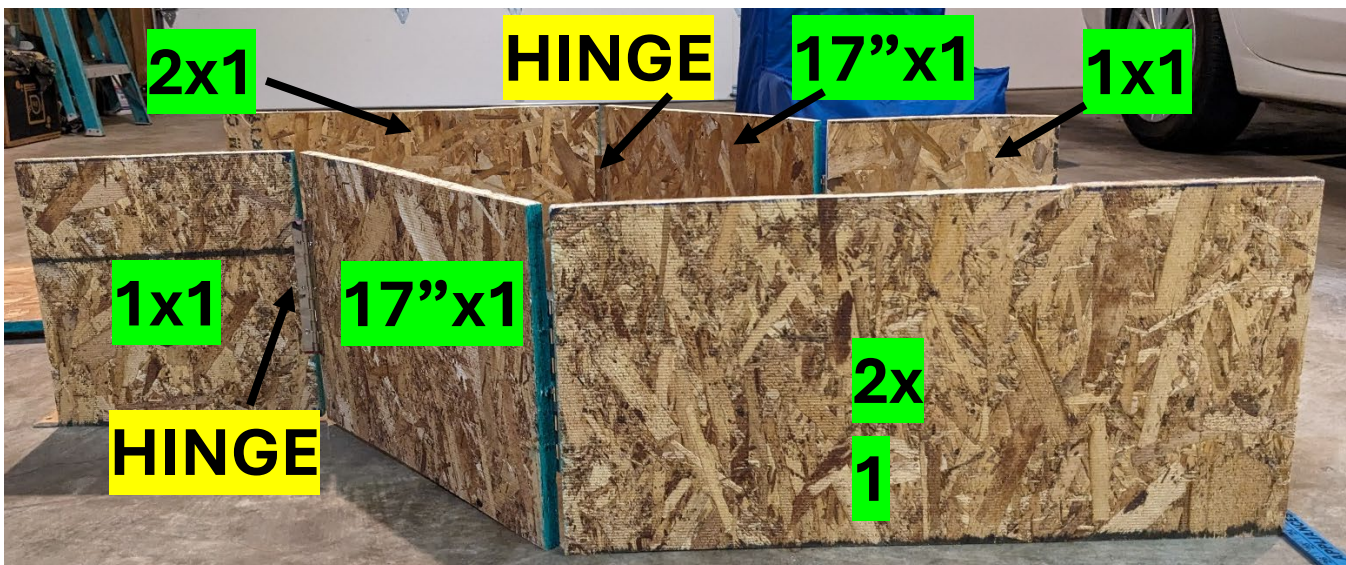

Blue side of field:

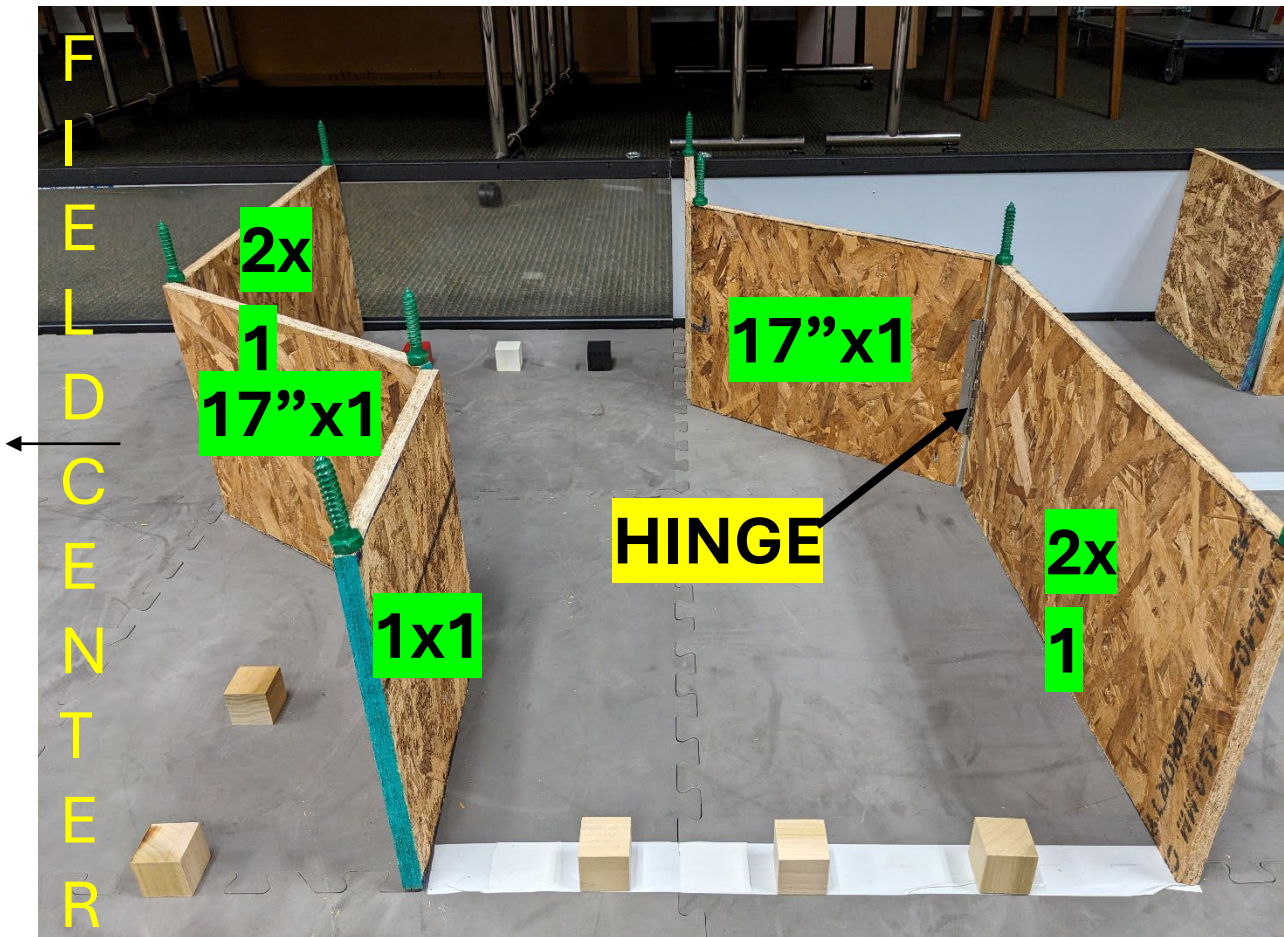

Layout of the Barriers:

The **innermost** Barrier wall of each Mining Region (the wall closest to the center of the field) should have the 2x1 plywood piece positioned up to (but not touching) the field perimeter. The **outermost** Barrier wall of each Mining Region (the wall closest to each team's base) should have the 1x1 plywood piece positioned up to (but not touching) the field perimeter.

As shown on the following images, for each Mining Region, the exterior edge of one board should be 24 inches from the exterior edge of the right board. These following images also show the exact placement of the blocks within the Mining Region, with each block's right edge aligning at the 6, 12, and 18 inch marks. The lumber blocks are placed on the white line at the entrance, and the ores are placed so each of their bottom right corners are 6 inches from the edge of the field.

